

INSTANT QUEUE MANAGER

Virtual IM Receptionist for IBM Lotus Sametime

Your Business Dilemmas

Do you need to increase productivity by giving employees immediate access to the help they need to do their jobs effectively?

Do you need to shorten your sales cycle and improve customer satisfaction by giving your customers immediate access to sales staff and customer support?

Instant Solution: Instant Queue Manager

Instant Queue Manager adds the benefits of presence awareness and real-time access to helpful experts to help desk and customer service operations.

- ◆ Provides a single source for immediate, expert assistance
 - ◆ Increases employee productivity
 - ◆ Improves customer satisfaction
 - ◆ Shortens sales cycles
 - ◆ Minimizes reliance on trouble tickets
- ◆ Displays queues on buddy lists or portal pages
 - ◆ Users can seek help from within Sametime or from anywhere in the world via a web browser
- ◆ No additional software on client desktop
 - ◆ Zero touch = instant deployment
- ◆ Uses Sametime awareness and chat UI
 - ◆ Zero user training required
 - ◆ Provides immediate access to helpful experts via IM
 - ◆ Experts can self-manage their availability to provide help
- ◆ Distributes Requests Evenly
 - ◆ Each expert assumes an equal share of the workload
 - ◆ Wait time is minimized

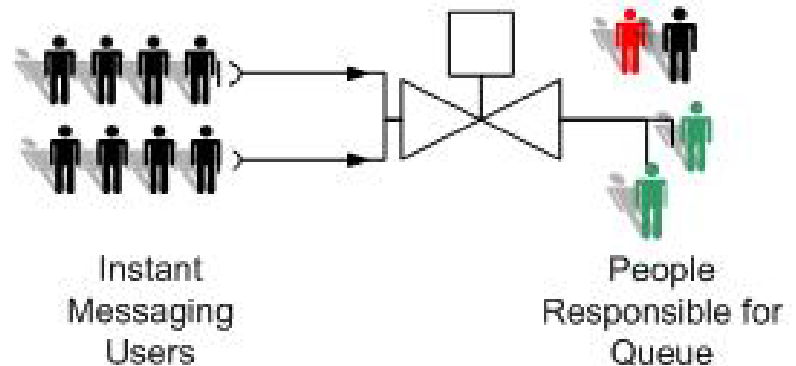

INSTANT QUEUE MANAGER

Virtual IM Receptionist for IBM Lotus Sametime

- ◆ Experts may reply with 'canned' responses from a central Notes database
 - ◆ Improves help desk efficiency
 - ◆ Ensures consistent answers to common questions
- ◆ All activity is logged to central database
 - ◆ Provides metrics on your ability to meet your target service levels
 - ◆ Tracks help desk staff efficiency for use in employee performance reviews
 - ◆ Automatically retains copies of all interactions for internal auditing and/or external compliance requirements

How it Works

- ◆ A bot alerts an expert (or group of experts) to a new request for help
- ◆ An expert accepts the request
 - ◆ Other experts are notified of the acceptance
- ◆ The conversation is logged to central database
 - ◆ Expert can immediately add comments to the record to indicate if the issue was resolved or whether additional action must be taken

"We are now able to easily route and manage real-time requests from our web site, without the need for any complex programming or Java expertise."

"The logging feature immediately lets us see who replied to which request and how many web-based queries we have handled."

"Instant Queue Manager instantly puts data at our users' fingertips so they can do their jobs faster and better."



About Instant Technologies

Instant Technologies specializes in developing innovative, enterprise-class compliance and productivity solutions for IBM Lotus Sametime and Microsoft Office Communications Server, including IM archiving, IM queue management, persistent chat rooms, IM bot development, buddy list administration, and more. Instant Technologies is a Lotus Advanced Business Partner and a Microsoft Registered Partner headquartered in Durham, NH.